

400 Series

Jensen
MIXERS

Installation

Operation and

Maintenance Manual

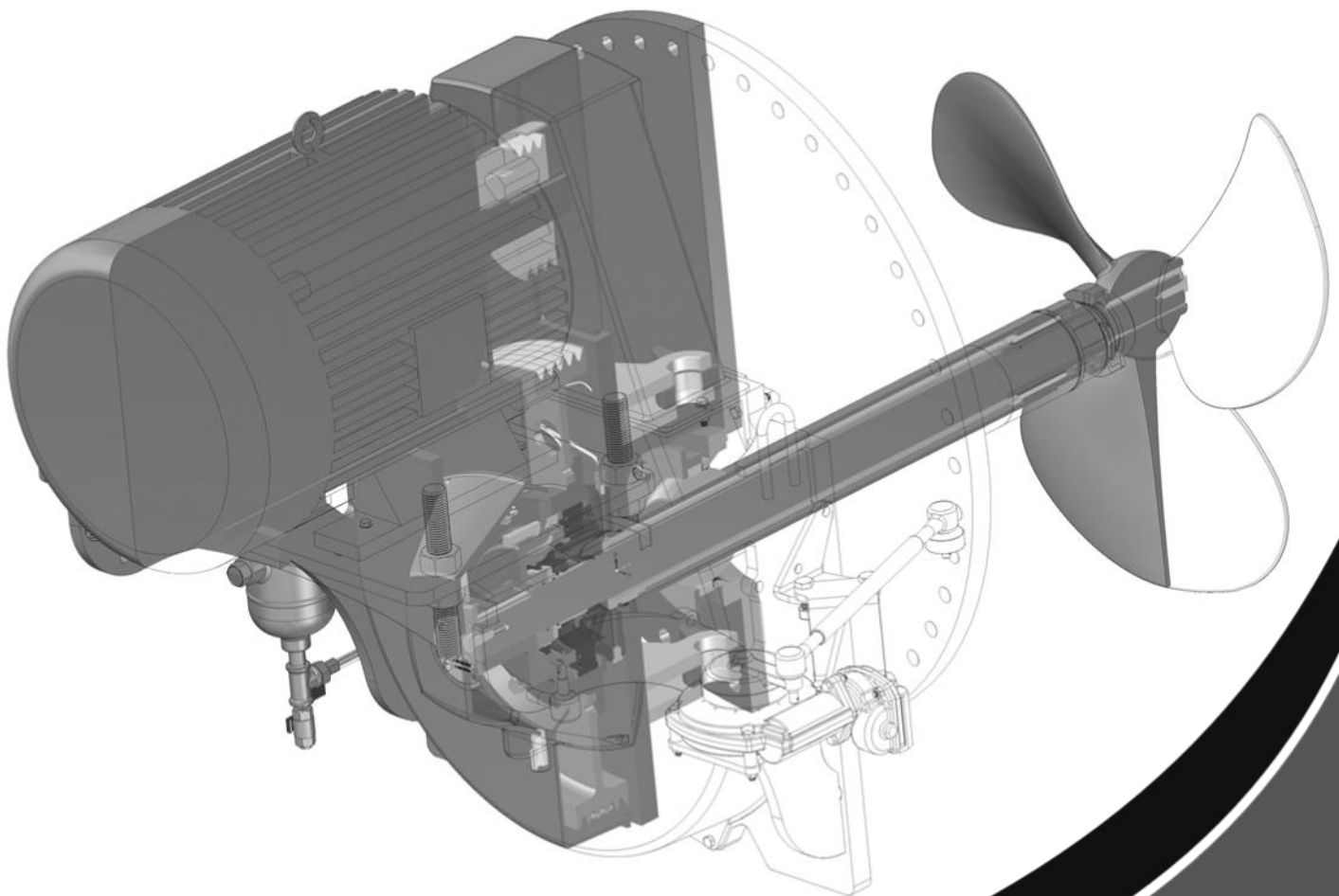

Jensen Mixers Int.
5354 South Garnett Rd.
Tulsa, OK. 74146

 II 2G c IIC T5

S16AC-4

04/06/17

When mixers are delivered, check for shipping damage.

Report damage to carrier and Jensen Mixers.

Installation, Operation, Maintenance

Installation Series 400 Fixed and Vari-Angle Mixers

- Remove blank manway plate from tank nozzle and check Jensen supplied mixer mount for correct size, hole location and orientation.
- Clean gasket surface on tank nozzle and mating flange on mixer mount.
- Mount propeller on shaft (secure both setscrews on propeller lock assembly) confirm manway is large enough for propeller to roll through opening. (See page 4 for propeller roll through opening specs.)
- Install gasket and bolt mixer mount to manway. No additional supports are necessary.
- For units with factory mounted motors, the installation is now complete.
- For units with the motor shipped separately or customers supplying their own motor; mount the motor to the mounting plate and loosely position the drive pulley on the motor shaft. Install belts and check alignment and belt tension as described on page 5.
- Re-install all belt guards.

Startup

Recommended Operation, Periodic Maintenance

- Make up the electrical wiring in such a manner that there is enough flexible cable from the rigid conduit to the mixer to allow the VA mixer, if VA mixer is being installed, full swing. Electrical hookup must be in accordance with existing electrical code for the area.
- Remove belt guards and check belt deflection and alignment before startup. See (Page 5.)
- Turn motor on for 5 seconds maximum, to check shaft or propeller rotation. The mixer shaft must turn clockwise when viewing mixer from behind, looking towards the tank.
- Once tank fluid is above mixer shaft, open AIR RELEASE valve (Pg. 10) to vent the trapped air and allow tank product to lubricate the seal.
- Start mixer after tank contents is 10 feet (3 meters) above the propeller. The only noise one should hear is that of the propeller moving the fluid in the tank and the hum of the motor. If any other noise is heard, shut down motor, investigate and correct.
- Be sure the latch bar bolts are tight, if VA mixer was installed. If any excessive vibration is detected, make sure the propeller tips are not less than 8" (203 mm) from any obstruction.
- Check the motor current with an amp meter. Check both electrical legs to be sure that the amperage is less than that printed on the motor name tag.
- Recheck belt deflection and tension after the first 8 hours of operation.
- Units with factory installed actuator, see actuator operation sheet.
- Units should be checked at least once within 24 hours of startup.

Recommended Operation:

- Mixers installed on tanks with existing sediment accumulation should be operated continuously as long as oil level is above 10 feet (3 meters) and sediment content in outgoing stream is acceptable. Angle variation from full left to full right and to the off center should be made periodically – once each month during continuous running. Recommended positions -30° to -5° to 30° then repeat
- For effective sediment control on clean tanks, start mixer 8 hours before pump-out. Continue until tank is half full. This procedure will need to be modified to suit climate and conditions. In controlling sediment, angle variation need be made only about once each month.

Periodic Maintenance:

- WEEKLY: Observe Center Sight Glass on Sentry System for fluid, this will be indication of seal issues.
- WEEKLY: Check external moving parts for abnormal wear.
- MONTHLY: With the mixer running, check for noise and vibration. (See Troubleshooting if occurs)
- MONTHLY or AS NEEDED: Check belt deflection and wear. Be sure the pulleys are not worn and are clean.
- QUARTERLY: Grease hinge zerk if Jensen Actuator is installed.

Propeller Clearance & Fluid Levels

Almost every vibration problem experienced with Jensen Mixers has proved to be a result of too little clearance between tank walls or floors and the mixer propeller. Operation of mixers with low fluid levels in the tank will cause air to be drawn into the propeller flow stream and will also cause vibration.

<u>Propeller Diameter</u>	<u>Fluid Level Above Propeller Centerline</u>	<u>Clearance between Prop Tip & Floor</u>
35" (889mm)	10' (3.1m)	12" (305mm)
32" (813mm)	8' (3.1m)	12" (305mm)
29" (737mm)	7' (2.1m)	12" (305mm)
26" (660mm)	6' (1.9m)	10" (254mm)
23" (584mm)	6' (1.9m)	8" (203mm)
20" (508mm)	4' (1.3m)	8" (203mm)

Propeller Manway Roll Through Clearances.

"H" Dimension is the measurement from the inside of the tank wall to the edge of manway.

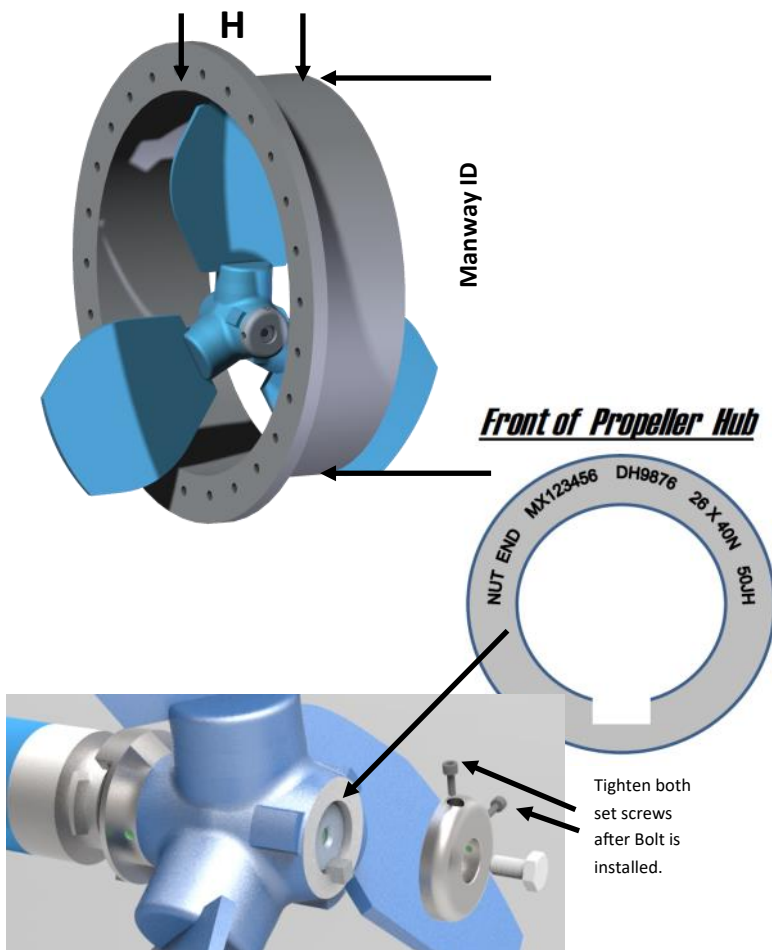

Manway depth	Propeller size /Manway I.D.						
	H	20	23	26	29	32	35
4	14	16	17	19	20	22	
5	15	16	18	19	21	22	
6	16	17	19	20	22	24	
7	16	17	19	22	24	25	
8	18	19	20	23	25	26	
9	18	19	20	24	26	28	
10	18	20	22	24	27	29	
11	18	21	22	25	27	30	
12	19	21	22	25	28	30	
13	19	21	22	26	29	32	
14	21	22	24	27	30	34	
15	21	22	25	28	30	34	

Example: A 29" propeller will rotate through a 23" opening provided the depth of opening is 8" or less

Motor Belt Alignment

V-Belt and Cog Belt Drive Maintenance:

- Check alignment of pulleys.
- Maintain uniform tension.
- Avoid heat above 140°F. (60°C)
- Keep drives well ventilated.
- Never use belt dressing.
- Worn sheaves reduce belt life.
- Do not allow oil on belts.
- Never force belts onto sheaves.
- Equalize slack before tightening by marking one side of each nut to aid in tracking nut turns.

BELT DEFLECTION SHOWN

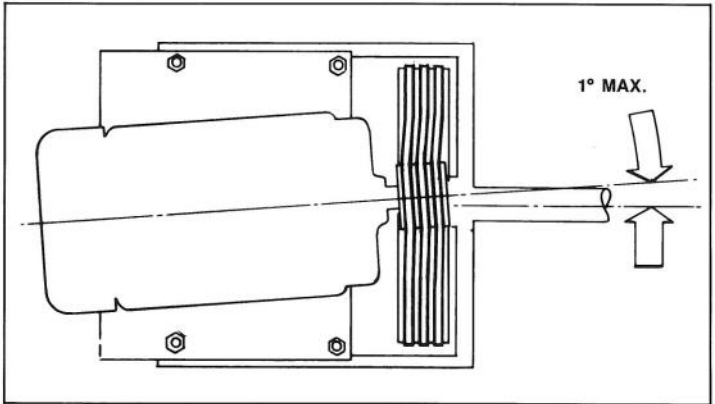
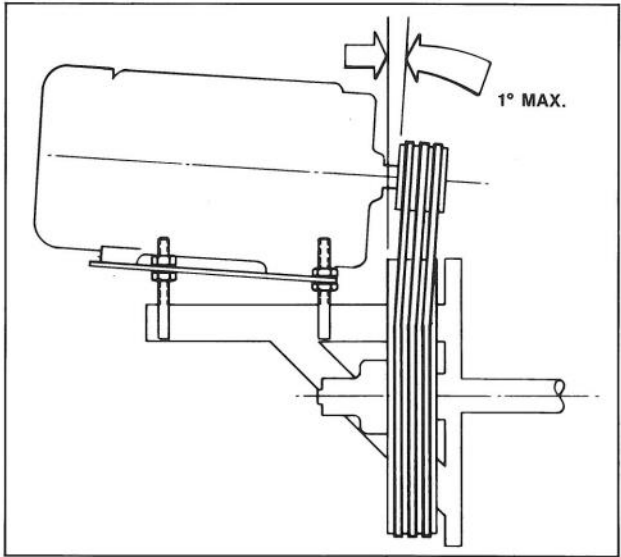
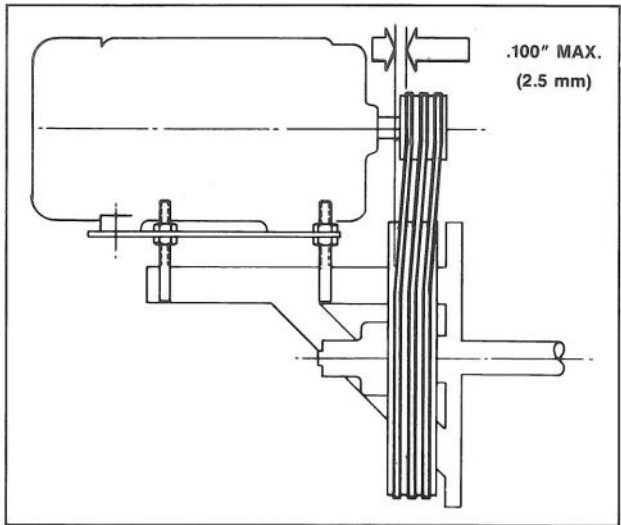
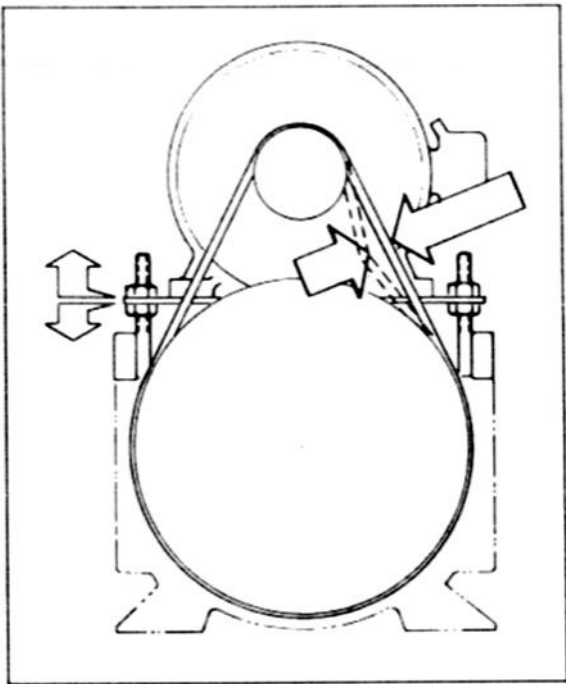

Model	Deflection	V-Belt Force	V-Belt Size	Cog Belt Force	Cog Belt Size
420	3/16 (4.5 mm)	3.3 to 4.8 lbs	3V450	NA	NA
450	¼ (6 mm)	5.0 to 7.5 lbs	3V710	8 to 10 Lbs	8MGT-1792-21
480	3/8 (9.5 mm)	5.0 to 7.5 lbs	5VX1000	18 to 20 Lbs	14MGT-2520-37

Repairs

Field Assembly Tool List:

Field service and inspection on Jensen Series 400 Mixers requires only basic hand tools.

The following list will allow removal of all major components.

	420	450	480
End Wrenches (2) Ea.	1/2, 9/16, 3/4	5/16, 1/2, 9/16, 3/4, 15/16, 1-7/8	5/16, 1/2, 9/16, 3/4, 15/16, 1-7/8
Hex Wrench (1) Ea.	3/16, 7/32, 1/2	3/16, 7/32, 1/2	3/16, 7/32, 1/2
Adjustable Wrench (1)	2" Jaw Open	2" Jaw Open	2" Jaw Open
Large Flathead Screwdriver	2 Required	2 Required	2 Required

All maintenance repairs should be performed with the mixer motor locked out and tank contents locked in. (See page 5-11 for lockout instructions.)

- **Main bearing** – Perform LOCKOUT PROCEDURE and remove seal. Remove all belt guards. Remove 4 hex socket head screws from the bearing retainer ring. The driven pulley along with bearing and pulley hub can be removed by pulling straight back. With the pulley assembly off, press out bearing from back side of hub and replace. Reverse above procedure for re-assembly.
- **Mechanical Seal replacement** see pages 5-10.
- **Belt replacement**—Remove all belt guards. Lower the motor base plate. Remove belts and replace. Retighten using belt alignment guide. (Page 4)

When the mixer is removed for repairs:

Shaft Bushing Inspection – (Item # 37 pre Sentry or #29 Sentry)

- Once the body has been removed, the inner sleeve which holds the shaft bushing can be removed. A groove is provided on the exposed end of the inner sleeve; a pair of screwdrivers may be used here to start the sleeve out. The shaft bearing is located inside the inner sleeve at the propeller end. If it is badly worn or scarred, it should be replaced.
- The bushing material is solid tungsten carbide for greatest resistance to wear in the most abrasive environments. If it is worn it will be necessary to replace the entire INNER TUBE ASSEMBLY.
- To reinstall the inner sleeve, position the lugs away from prop, vertically, then push the sleeve in until it stops. Replace the O-ring on the outside of the sleeve.
- We recommend that when mixing light products such as gasoline, or materials containing heavy abrasive characteristics, the inner sleeve should be removed and the TC bushing inspected.

Shaft Wear Sleeve – (Item # 38 pre Sentry or #31)

- All Jensen Series 400 mixers are equipped with a tungsten carbide reversible shaft wear sleeve. When the tank is out of service for periodic maintenance, the wear sleeve should be inspected. If it is badly worn or scored it should be reversed. To change the sleeve, remove the propeller and shaft lock bushing, reverse the wear sleeve and assemble.

JENSEN OFFERS A FULL FACTORY RECONDITIONING PROGRAM, CONTACT YOUR LOCAL REP FOR DETAILS.

400 (Pre 2014 Sentry System) MECHANICAL SEAL CHANGE

Jensen Serial Numbers before
480 Mixer DR-101 to DR-1123
450 Mixer DO-101 to DO-781

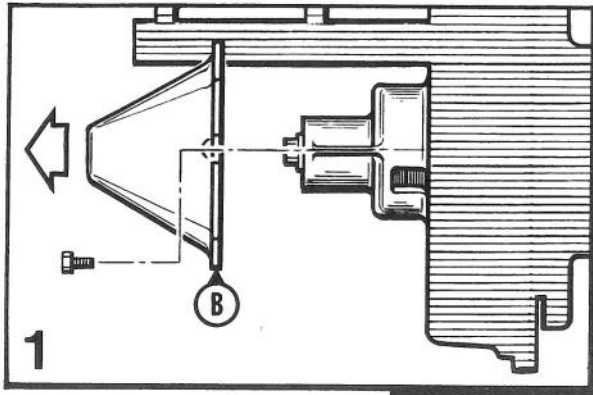

1. Remove yoke cover.
2. Remove yoke bolts.
3. Pull the yoke back to stop ($\frac{1}{2}$ " to $\frac{1}{4}$ "), then turn it **counter-clockwise** till lock engages and shaft stops (90° or more). This seals off the tank contents. If the yoke cannot be pulled back by hand, jack screws are provided in the yoke.
4. Remove shaft bolt, yoke and drive key.
5. Remove the mechanical seal.

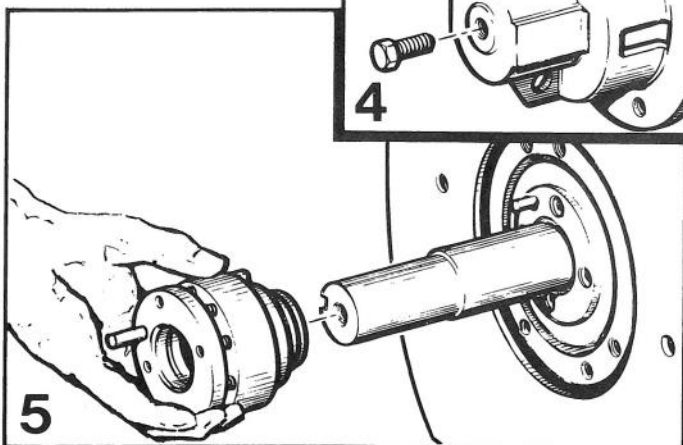
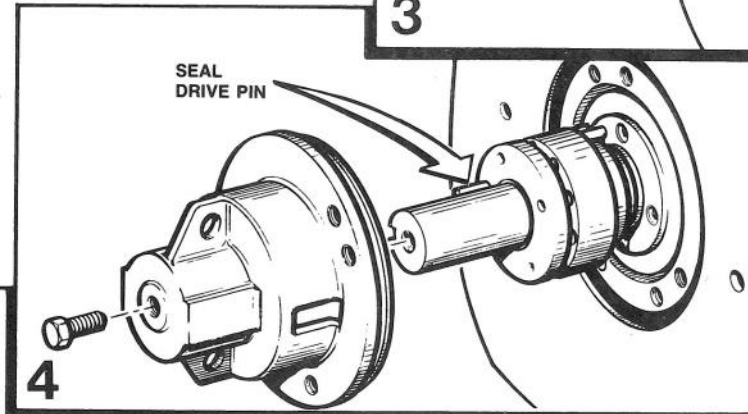
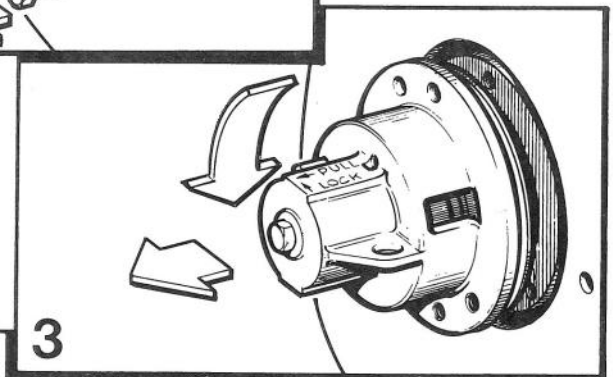
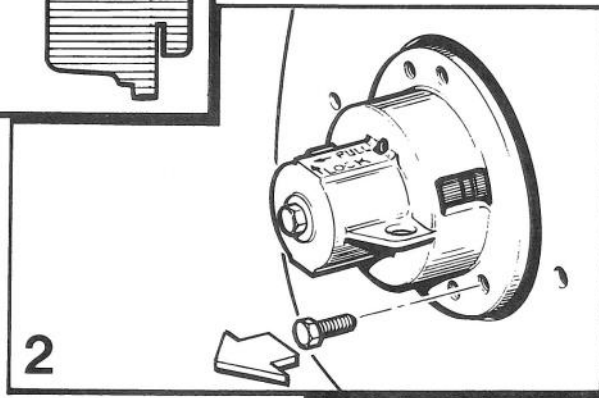

Note that seal drive pin is located over the shaft keyway. If the seal is to be replaced, push new seal on to shaft and reverse the preceding steps. Be sure that the seal drive pin extends into the hole above the keyway in the drive yoke.

Jensen 400 series 2014-Older (Pre-Sentry System)

Jensen Serial Numbers
 480 Mixer DR-101 to DR-1123
 450 Mixer DO-101 to DO-781

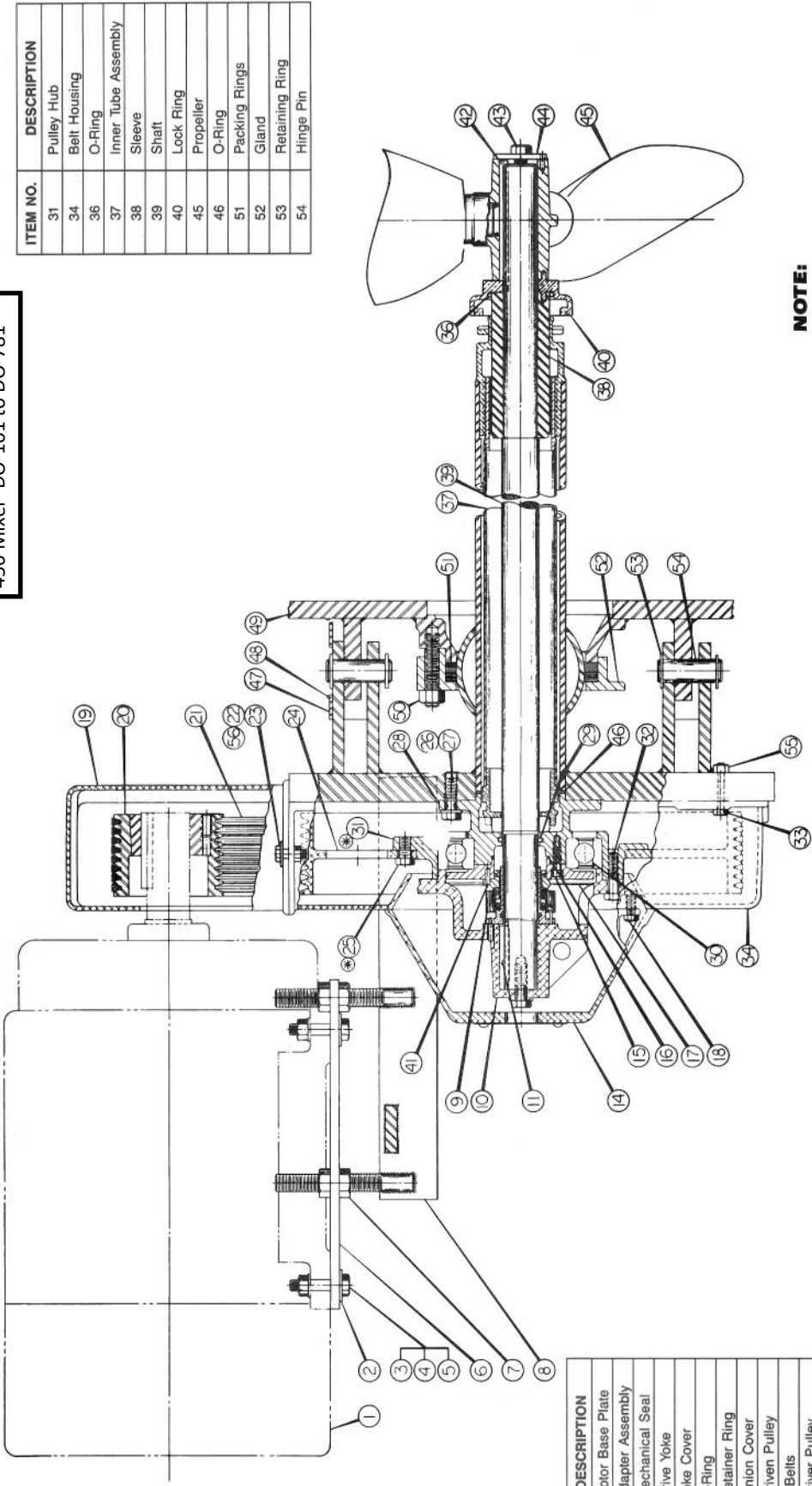

ITEM NO.	DESCRIPTION
31	Pulley Hub
34	Belt Housing
36	O-Ring
37	Inner Tube Assembly
38	Sleeve
39	Shaft
40	Lock Ring
45	Propeller
46	O-Ring
51	Packing Rings
52	Gland
53	Retaining Ring
54	Hinge Pin

ITEM NO.	DESCRIPTION
6	Motor Base Plate
8	Adapter Assembly
9	Mechanical Seal
10	Drive Yoke
14	Yoke Cover
16	O-Ring
17	Retainer Ring
19	Pinion Cover
20	Driven Pulley
21	V-Belts
24	Driver Pulley
28	Body
29	O-Ring
30	Main Bearing

NOTE:

When ordering parts give:
 Mixer Model & Serial Number, Item Number, Part
 Name and Part Drawing Number.

ITEM #	PART NAME
6	MOTOR BASE PLATE
8	ADAPTER ASSEMBLY
8-3	MALE END BUSHING
9	MECHANICAL SEAL
10	YOKE ASSEMBLY
11	KEY
14	YOKE COVER
16	"O" RING
17	RETAINER RING
19	COVER
20	DRIVER PULLEY
21	BELT
24	DRIVEN PULLEY
28	BODY
29	"O" RING
30	MAIN BEARING
31	PULLEY HUB
34	BELT HOUSING
36	"O" RING
37	INNER TUBE ASSY
37-4	TC - BUSHING
38	SLEEVE
39	SHAFT
40	LOCK RING

ITEM #	PART NAME
42	KEY
43	CAPSCREW
44	WASHER
45	PROPELLER
46	"O" RING
51	PACKING RINGS
52	GLAND
53	CAPSCREW
54	HINGE PIN INTERLOCKING
57	"O" RING
70	FERRULE SEAL
80	CAPSCREW
90	OIL SEAL SENTRY SYSTEM
91	SEAL BOOT ASSEMBLY
92	SIGHT TUBE
93	SEAL DRIVE RING
94	BELT HOUSING
95	BEARING LOCK WASHER
96	BEARING SPACER
97	SEAL DRIVE RING

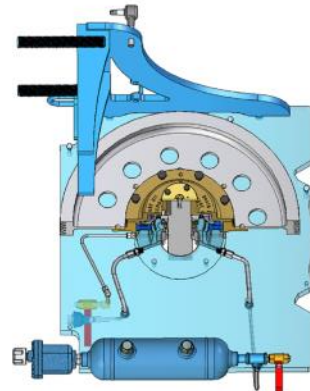
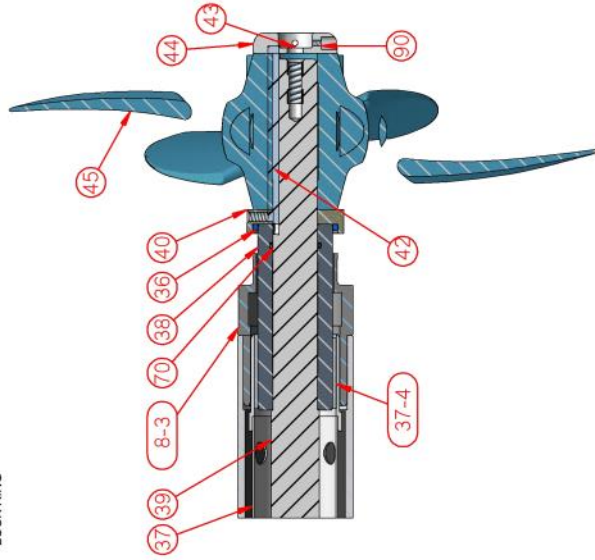
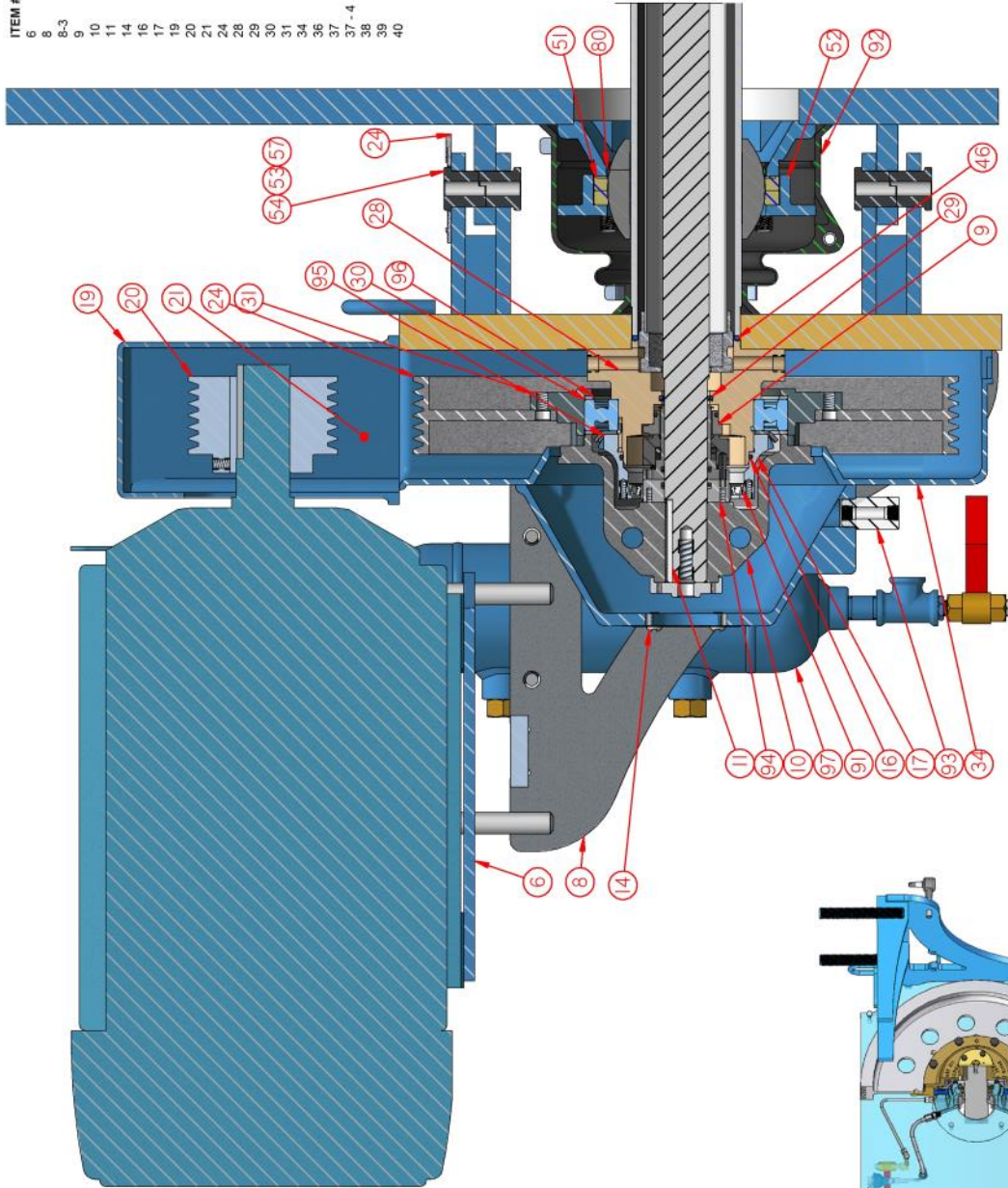

SEE S168S FOR REFERENCE

PROPRIETARY AND CONFIDENTIAL
 THE INFORMATION CONTAINED IN THIS DRAWING IS THE SOLE PROPERTY OF JENSEN MIXERS INTERNATIONAL, INC. REPRODUCTION IN PART OR AS A WHOLE WITHOUT THE WRITTEN CONSENT OF JENSEN MIXERS IS PROHIBITED.

TITLE: 480/450 VA ASSY
DRAWING NO. S12M

SHT. 1 OF 1

REV. DATE: 3-10-16
 REV: 7

Jensen Mixers International, Inc.
 P. O. BOX 470988 TULSA, OKLAHOMA 74147

400 (Sentry System) MECHANICAL SEAL CHANGE

Jensen Serial Numbers AFTER DR-1123 (480 Mixer) DO-781 (450 Mixer)

NOTE: Complete seal exchange can be aided by removal of all covers.
TAKE NECESSARY STEPS TO CONTAIN PRODUCT

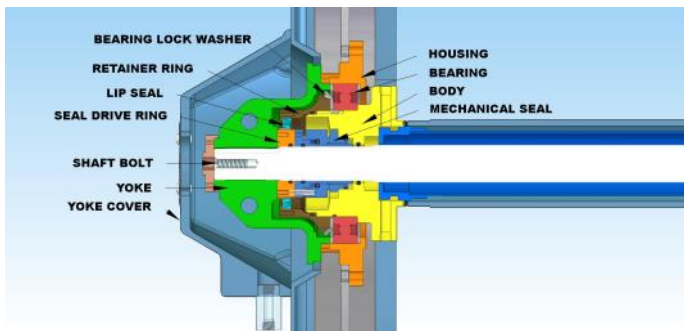

1. If tank product is noticed in one of the TOP TWO sight glasses follow the steps below.

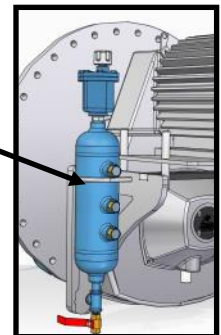

TOOLS REQUIRED

- 2" ADJUSTABLE WRENCH
- 1/2" OPEN ENDED WRENCH OR SOCKET
- 3/4" OPEN ENDED WRENCH OR SOCKET
- LARGE FLAT HEAD SCREWDRIVER
- Two 1/4-20 3"-4" BOLTS

2. Remove YOKE COVER.

(1/2" OPEN WRENCH)

Remove YOKE bolts.

(3/4" OPEN WRENCH)

Position YOKE with SEAL PIN HOLE at 12 O'clock Position.

2.

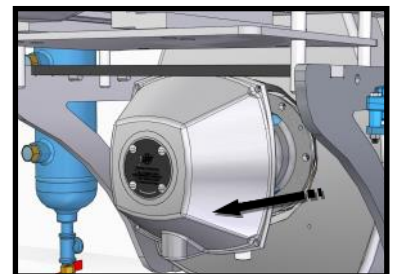

3. Perform Lock-Off by

- A. Pulling the YOKE back to stop. (Approximately 1 inch).
TANK PRODUCT MAY BLEED DURING THIS OPERATION.
- B. Turn YOKE counter-clockwise until SHAFT stops (Approximately 90°). Placing pin at 9 o'clock position.

Mixer will be LOCKED OFF at this point AND CAN BE CONFIRMED BY OPENING THE AIR RELEASE VALVE. (Pg 11.)

3.

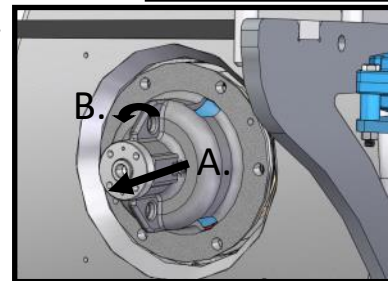

4. Drain RESERVOIR by removing the plug and open the release VALVE HANDLE. A

5. Remove VENT PLUG in front of the Mixer Bulkhead.

This will accelerate draining the Reservoir tank. B

4. 5.



6. Remove SHAFT BOLT (3/4" OPEN WRENCH) , YOKE, and KEY

Remove SEAL DRIVE RING. (A solid pull by hand will generally be sufficient.)

Two 1/4-20 tapped holes are provided to aid in removal.

MECHANICAL SEAL can normally be reached and replaced at this point.

Two 1/4-20 holes have been drilled and tapped into MECHANICAL SEAL Body to aid in removal.

6.

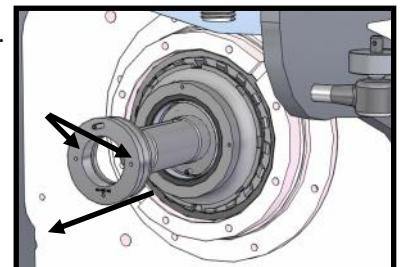

NOTE: Use caution to avoid damage of Lip Seal when removing MECHANICAL SEAL.

7A NOTE;

- Extreme caution should be taken to not damage the Inner LIP-SEAL, failure will require replacement of LIP-SEAL.
- Reverse steps after installation of new MECHANICAL SEAL.
- **WARNING: YOU MUST ALIGN SEAL DRIVE RING HOLE WITH SEAL DRIVE PIN.**
- **PERFORM SYSTEM FLUSH OF SENTRY SYSTEM Pg. 11**
- If debris is unreachable continue with steps 8-12 SEAL CHAMBER CLEANING.

SEAL CHAMBER CLEANING

REMOVE BELT HOUSING COVER

8. Locate BEARING LOCK WASHER and pry TAB up clearing the RETAINING RING.

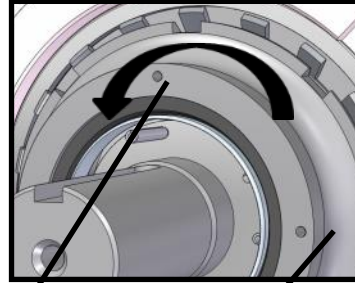
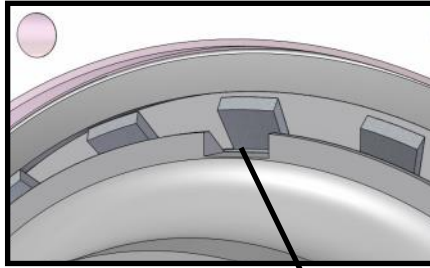

9. Partially thread in 1/4-20 bolts (shown with arrows) to aid in turning RETAINING RING with screwdriver.
UNSCREW BY TURNING TO LEFT 4-5 ROTATIONS

NOTE: TAB may not be in locked the 0° position and may be reinstalled in any of the 8 locking positions.

10. With RETAINER RING removed Remove foreign matter. Replace LIP SEAL if necessary. Fluid ports can be checked and cleaned.

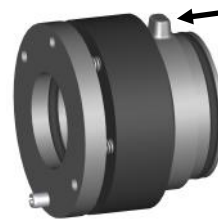
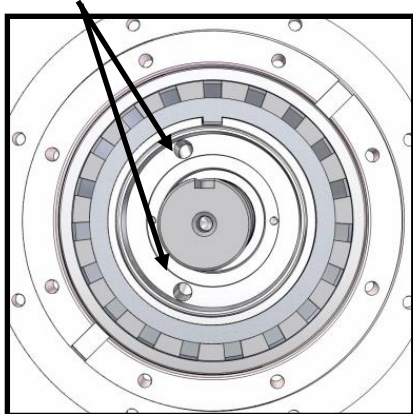
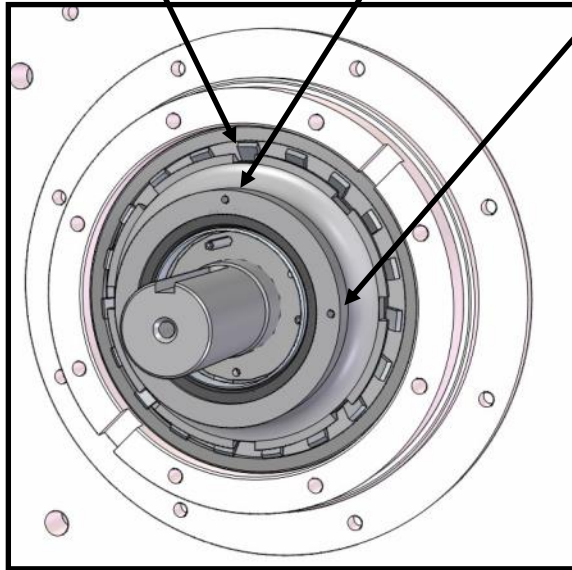

11. Install NEW MECHANICAL SEAL noting the stationary pin on SEAL.

NOTES AFTER NEW SEAL INSTALLATION:

- RETAINER RING is tightened to 1/8 turn after snugged.
- Refill lubrication reservoir with 32Oz. of lubrication fluid. (Royal Purple FDA 46 or similar). SEE SENTRY STARTUP AND FLUSH PROCEDURE. Pg. 11

MECHANICAL SEAL stationary pin should be in contact with either anti-rotation pins located at the 3 or 9 O'clock position in the seal chamber.

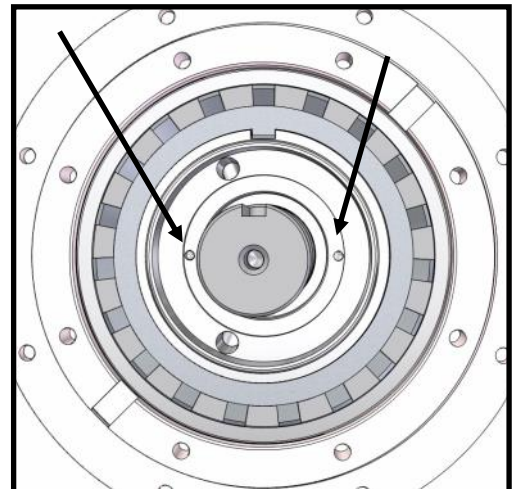
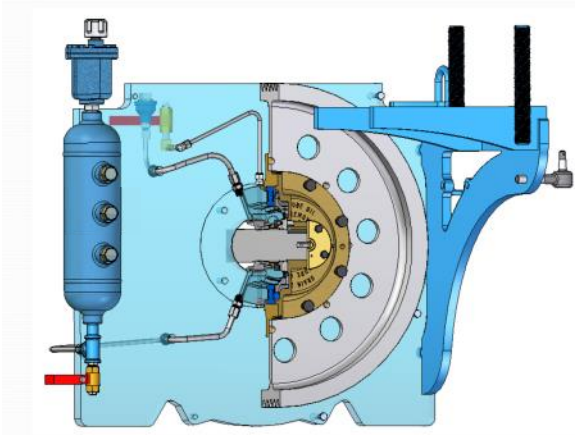

Jensen Sentry System Recharge/Flush Procedure

Jensen's dual purpose Sentry System is designed to provide lubrication to the Seal area and provide a visual notification of a Seal failure.

Know your system

Upper Leak Detection Glass.

If product is visible a leak is present.

Lower Lubrication Level Glass.

Fill with lubrication until visible in the center this glass.

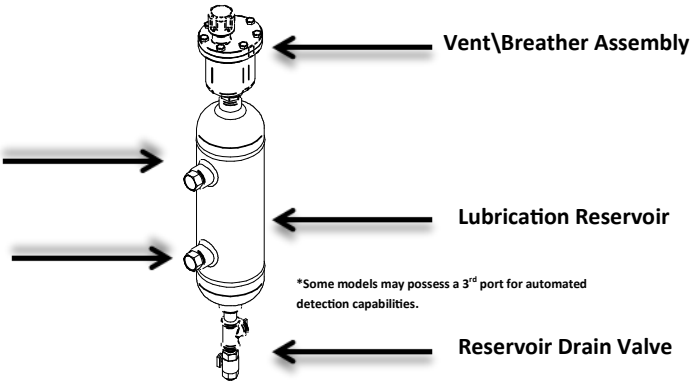

Air Release Valve

MODEL 480 is shown here.

This Valve opens to the "Tank Product Side" of the Sentry System. It is used to "bleed" the Shaft Tube of air and prevent Air Lock during a new installation or if Tank has been lowered below the Shaft Tube. (Removal of pipe plug is necessary.)

NOTE: Model 450 Air Release Valve and Leak Detection Inlet are swapped left to right. Air Release Valve is pointed in a downward direction.)

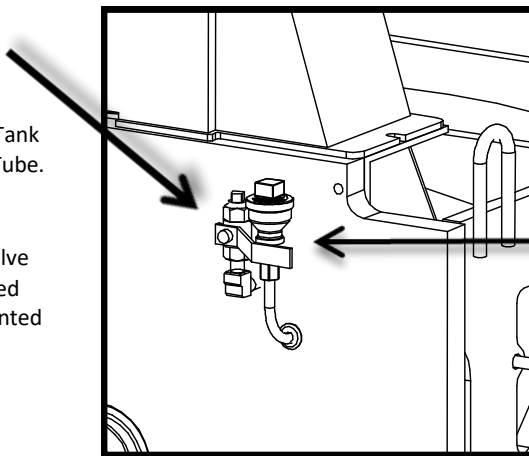

Leak Detection Inlet

Removing the pipe plug provides access to the Seal Cavity and Lubrication Reservoir.

This is the fill point for adding seal lubrication.
FILL WITH :
ROYAL PURPLE POLY GUARD FDA 46
(OR COMPARABLE)

This will also be the Fill Point for a System Flush. A System Flush should be performed at every Lubrication Oil change and every Seal change.

SYSTEM FLUSH

The purpose of a System Flush is to clean the seal area of debris and other unwanted contaminants that may have collected in the Seal area.

To perform the system flush a containment vessel (bucket) and an adjustable wrench will be needed. **Mixer unit must be powered down.**

- 1) Remove the plug from the Leak Detection Fill Inlet. Item 10
- 2) Remove the plug from the base of the Valve (Item 7). Place containment vessel under the Reservoir Valve and raise the valve handle to the open position and empty contents into containment vessel.
- 3) With valve open, pour FLUSHING fluid into Leak Detection Fill Inlet (Jensen recommends flushing with the Royal Purple Poly Guard FDA 46) . Add approximately 2-3 quarts and let the system drain.
- 4) Close Reservoir Valve and replace Inlet plug. Refill Reservoir to center of lower sight-glass. Power up mixer for 3-5 minutes.
- 5) Remove Inlet plug and open Reservoir Valve to drain contents. Add 2-3 quarts and let the contents drain. Close Reservoir Valve, replace Reservoir Valve plug and fill to center of the lower sight-glass. Replace inlet plug and power up Mixer. This will complete the System Flush.

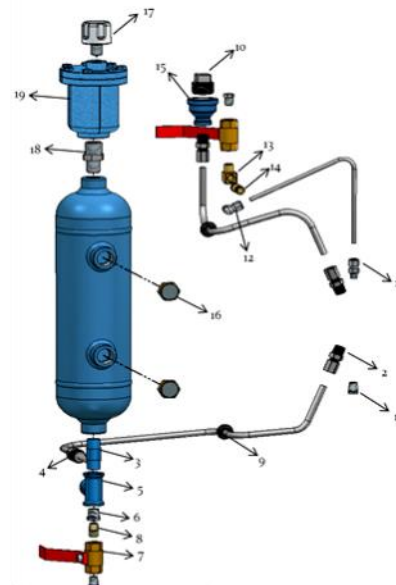

TORQUES

Fastener Location	420 Bolt Size/Torque	450 Bolt Size/Torque	480 Bolt Size/Torque
Belt Cover	$\frac{5}{16}$ 75 in-lb	$\frac{3}{8}$ 120 in-lb	$\frac{3}{8}$ 120 in-lb
Yoke / Hub	$\frac{1}{2}$ 30 ft-lb	$\frac{1}{2}$ 30 ft-lb	$\frac{1}{2}$ 30 ft-lb
Pulley / Hub		$\frac{1}{2}$ 30 ft-lb	$\frac{1}{2}$ 30 ft-lb
Body / Adapter	$\frac{1}{2}$ 30 ft-lb	$\frac{1}{2}$ 30 ft-lb	$\frac{5}{8}$ 70 ft-lb
Yoke & Prop / Shaft	$\frac{1}{2}$ 30 ft-lb	$\frac{1}{2}$ 30 ft-lb	$\frac{1}{2}$ 30 ft-lb
Bearing Retainer / Body	$\frac{5}{16}$ 6ft-lb	$\frac{3}{8}$ 10 ft-lb	$\frac{5}{16}$ 75 in-lb

Trouble Shooting Guide

1. Oil leakage from belt covers	<ul style="list-style-type: none"> A. Faulty or worn mechanical seal. B. Faulty O-Ring.
2. Noisy Belts	<ul style="list-style-type: none"> A. Misaligned motor. B. Oil on belt wearing surface. C. Loose belt.
3. Vibration If Vibration above .5 IN/SEC PEAK LEVELS is observed shut unit down.	<ul style="list-style-type: none"> A. Not enough clearance between propeller and tank wall. B. Bent or damaged propeller blade. C. Not enough fluid above mixer shaft. D. Bad main bearing. E. Worn shaft bearing. F. Motor running backwards. G. Diffuser or other inlet pointed toward mixer. H. Change of Tank fluid conditions.
4. Excessive belt wear	<ul style="list-style-type: none"> A. Check for belt slip or worn pulley. B. Check for oil or rubber solvent on belt pulleys. C. Check for heat or chemical fumes. Belt should not get above 140 F. (60 C) D. Check motor misalignment. E. Check Belt Tension.
5. Hot electric motor	<ul style="list-style-type: none"> A. Current overload. B. Bad motor bearing. C. Change of Tank fluid conditions.

Material Standards

Parts & Materials	American	British	German
Cover & Housing			
Aluminum Casting 356-T6	ASTM B108 Cl. SG70A		DIN 1725
Aluminum Casting 319F	ASTM B108 Cl. SC64D		DIN 1725
Body			
Iron Casting	ASTM A48 Cl. 25		DIN 1693
Adapter			
Carbon Steel Plate	ASTM A283 Gr. D	BS.4360	DIN 17100
Round Electric Weld Tube	ASTM A500 Gr. B		
Weld Filler Rod	ASTM A233 Type 7024		
Weld Filler Rod	ASTM A316 Type 7018		
Motor Mount			
Carbon Steel Plate	ASTM A283 Gr. D	BS.4360	DIN17100
Carbon Steel Square Type	ASTM A500 Gr. B		
Weld Filler Rod	ASTM A233 Type 24		
Mixer Mount			
Carbon Steel Plate	ASTM A283 Gr.D	BS.4360	DIN 17100
Shaft			
Stainless Steel Rod	ASTM A182		
Propeller			
Cast Steel	ASTM 216 Gr. 70		
Weld Filler Rod	ASTM A233 Type 7024		
Lock Ring & End Bushings			
Stainless Steel Type 316SS	ASTM A351 Gr. CF8M		
Bolts & Nuts	ASTM A307		
Stainless Steel Gr.2	ASTM A449		DIN 1711
Alloy Steel Gr.5			
O-Rings			
Viton GFLT	ASTM D2000-7B Spec. AMS 7278		

LONG TERM STORAGE

Jensen recommends long term (more than 90 days) storage procedures to protect mixers from atmospheric corrosion, physical damage and other harmful effects. Proper storage is especially important in corrosive or high humidity environments. Store and maintain related equipment (motors, control panels and similar devices) supplied by Jensen according to manufacturers' instructions. Failure to store and protect Jensen mixers properly may void any warranty, expressed or implied.

Pre-storage Inspection

When mixers are delivered, check impellers, impeller shafts and gearbox for shipping damage. Report damage to carrier and Jensen Mixers. Protect any carbon steel components from corrosion and check protective shipping coatings. Renew if necessary. Use heavy grease with corrosion inhibitor or thick spray such as Holt Lloyd Corp. LPS-3. New gear drives do not require additional internal protective procedures if storage is less than 90 days.

Storage Locations

Each type of storage location requires different procedures.

- Location 1 (preferred): a dry, enclosed, temperature and humidity controlled environment. Relative humidity of 40% or lower is ideal.
- Location 2 (acceptable): a dry, enclosed area such as a warehouse. (Marginally acceptable is an open shed with concrete floor).
- Location 3 (not recommended): outdoors under waterproof covering or mounted in operating location.

Storage Preparation and Maintenance

Jensen recommends the customer store mixers mounted on factory-provided skids in original crating.

1. Store each drive unit in its operating position, then fill gearbox to proper level with recommended lubricant. Rotate coupling until drive output shaft makes two complete revolutions.
2. Connect motor heaters, if supplied to a proper power source.
3. On side-entering mixer drives without motors installed, cover coupling half with heavy plastic sheet or bag and secure with cord or adhesive tape. On 500 Series mixers, wrap exposed mechanical seal with paper impregnated with corrosion inhibitor, then overwrap with plastic sheet. Cover motors and mixers with plastic or tarpaulins; secure.
4. Check at 30-day intervals. Rotate motor shafts and rotate couplings for three or more complete rotations of output shafts.
5. Store and maintain mixers according to location-specific instructions.

Location-Specific Storage Instructions

Location 1. Perform preparation and maintenance step 4 above.

Location 2. Cover motor completely but do not seal off to prevent accumulation of moisture. Cover gear drive securely. Extreme conditions may require use of portable dehumidifiers or placement of renewable desiccant bags under coverings.

Location 3. Cover motor completely but do not seal off to prevent accumulation of moisture. Cover gear drive securely. Secure all coverings against wind and rain. Extreme conditions may require placement of renewable desiccant bags under coverings.

Preparation for Service after long term storage:

1. Remove all protective materials and coverings. Wipe off dirt and oil.
2. Check greased bearings; re-grease if necessary.
3. Pour 32oz. tank compatible lubrication fluid into air vent to pre-lubricate seal. Hand rotate mixer through three full prop revolutions.
4. If applicable: Drain 10 percent of storage lubricant volume to remove condensed moisture. Adjust lubricant level with proper lubricant. Putting mixers in service with contaminant-free storage lubricant is permissible.
5. Check alignment of motor couplings. Follow procedures in manual.
6. Review mixer manual thoroughly and follow installation, start up and operating procedures.

LIMITED WARRANTY

Jensen Mixers are warranted against defects in materials or workmanship for a period of 12 months following date of purchase. This warranty is limited to replacement or repair of the agitator by Jensen only and does not cover consequential damages, removal, freight or re-installation. Electric motors are warranted by their respective manufacturers and are excluded from the Jensen warranty.

- Jensen will repair or replace, without charge, any part or parts which prove to be defective, under normal and proper use, within twelve months from the date of shipment.
- Jensen will not be held liable for any claims or charges for labor and/or parts resulting from repair or modification of Jensen products without prior written approval.
- Sub-assemblies installed on Jensen mixers, but not manufactured by Jensen, are covered by the original manufacturer's guarantee and are excluded from the guarantee.
- In no case shall Jensen's liability exceed the cost of repair or replacement of the mixer involved.
- Jensen will supply increased horsepower or additional mixers, without charge, should any mixer fail to satisfactorily perform the process for which it was recommended.
- Mixers must be installed and operated in accordance with Jensen's formal recommendation.
- All pertinent process data must be supplied to Jensen prior to the issuance of a formal recommendation.
- Recommendations issued by Jensen representatives, or agents, shall not be binding unless confirmed, in writing, by Jensen.
- It shall be Jensen's prerogative to determine what course of action is most satisfactory in the event of a claim on the process guarantee.
- The process guarantee shall be valid for twenty-four months following the date of shipment.
- In no event shall Jensen be liable for special or consequential damages.
- No other guarantees ,express or implied, shall be applicable.
- This guarantee applies only to mixers manufactured after July 1, 1969.

MIXER SPECIFICATIONS

ATEX NOTES:

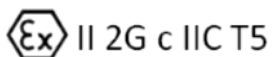

- If units are operated in ATEX Zone1 Belts should be checked weekly.
- Maximum RPM430 @ 60Hz
- Maximum RPM360 @ 50Hz
- Maximum Torque 680/480 221 Lbs-Ft
- Maximum Torque 450 118 Lbs-Ft
- Caution: Ambient temperature range of -20°C to 40°C
- 1a Caution: Units must be operated submerged
- 1b Bearing technical sheets are included in document packet.
- Caution: Bearings have a L10 calculation of 120,000 hours and should be changed based on duty cycle.
- 1c Caution: When operated in Zone 1 gearbox oil level or belt alignment should be checked weekly, otherwise check monthly.
- 1d Caution: Do not allow objects to obstruct the rotation of the propeller
- 2b Caution: Lubrication must be >150C flash point with a weight of 70-90

MOTOR SPECIFICATIONS

<u>MIXER MODEL</u>	<u>MAXIMUM RPM 50Hz/60Hz.</u>	<u>MAX HP SIZE</u>	<u>HORSEPOWER-RANGE</u>	<u>MAXIMUM TORQUE</u>
480	1475/1720	75	40-75HP	221 LBS-FT
450	1475/1720	30	5-30	118 LBS-FT
420	1475/1720	10	5-10	88 LBS-FT

THIS EQUIPMENT HAS BEEN EVALUATED TO THE FOLLOWING STANDARDS.

EN 13463-1: 2009, EN13463-5: 2011

NOTES

Placement for Jensen Mixers

Blending Service

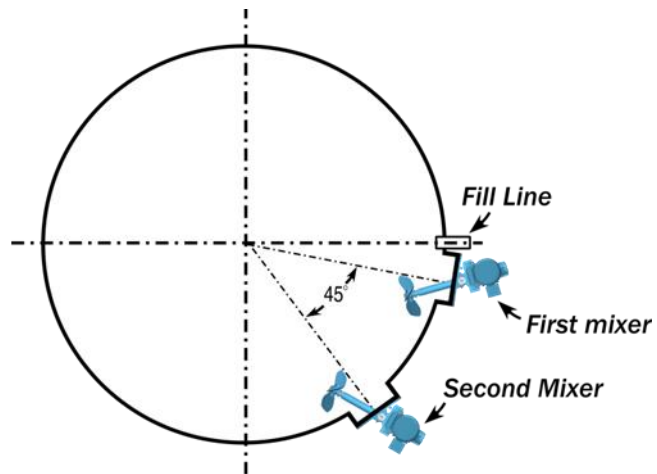

Locating the mixer(s) approximately 15 degrees to the left of the Fill Line compliments mixer performance and encourages product to be pulled into the mixer propeller and quickly dispersed into the tank.

NOTE: ALL MIXERS MUST BE SET IN SAME DIRECTION.

Sediment / BSW Management Service

1 MIXER

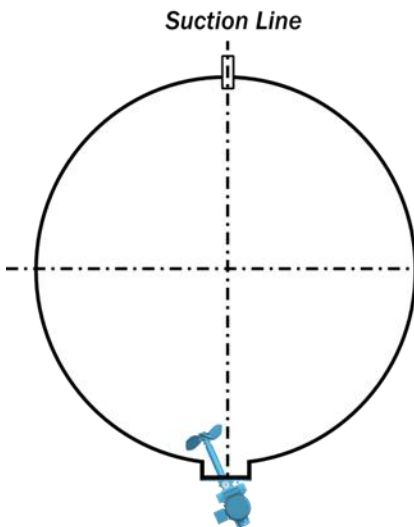

2 MIXERS

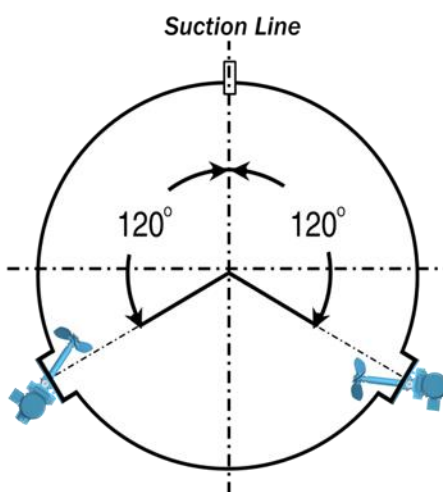

3-5 MIXERS

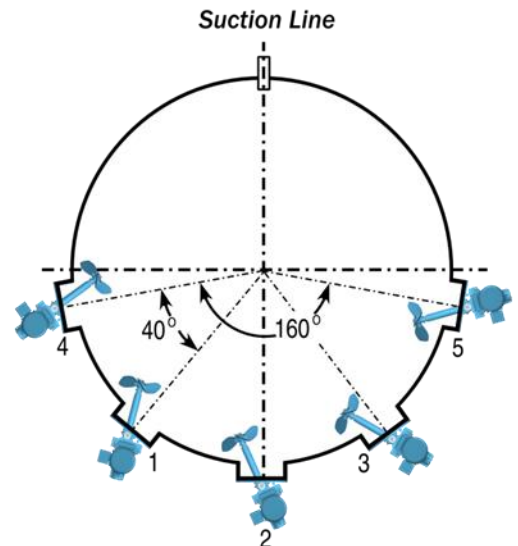

Locating the mixer(s) at the opposite side of the Suction Line the allows the user to take advantage of the natural cleaning that will occur due to product being drawn from the tank.

NOTE: ALL MIXERS MUST BE SET IN SAME DIRECTION.

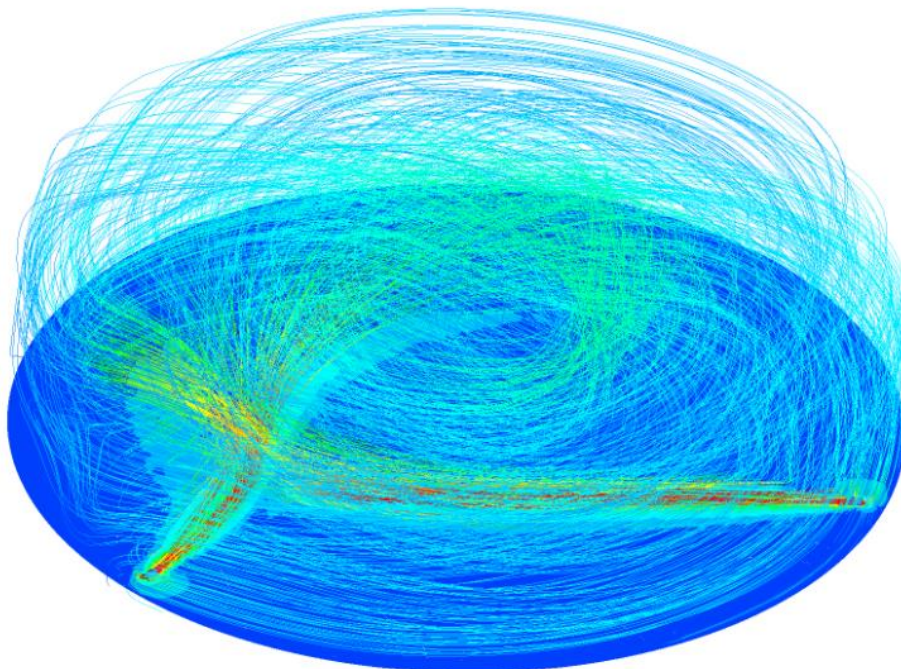
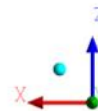
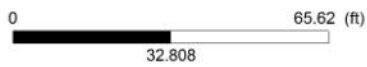
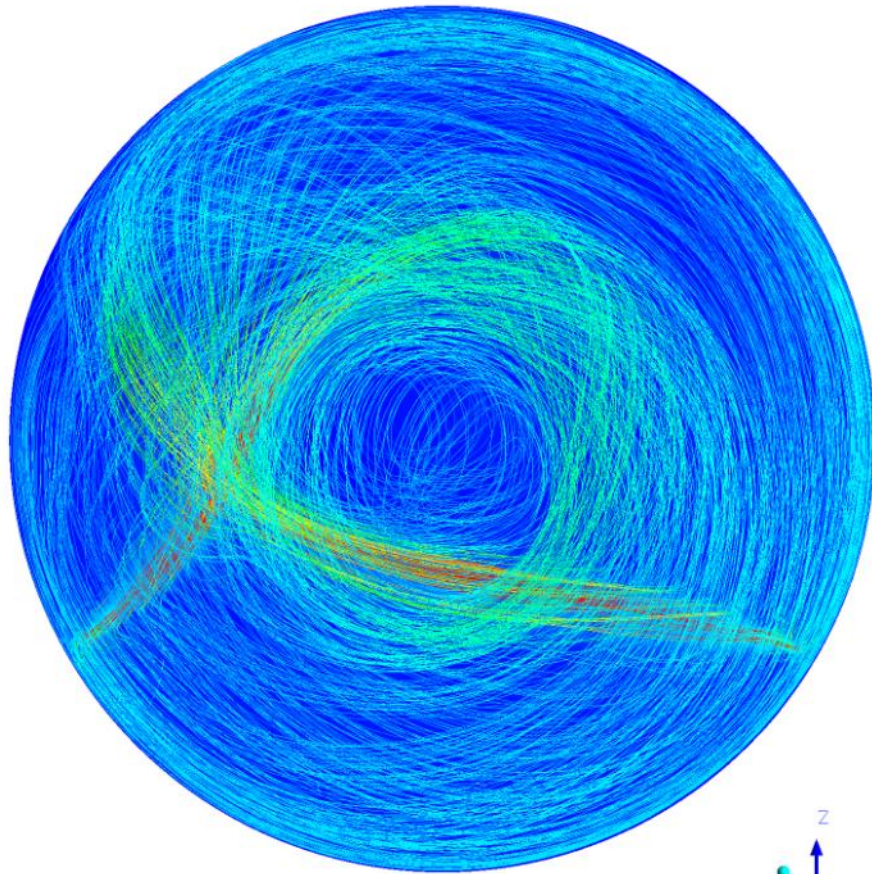

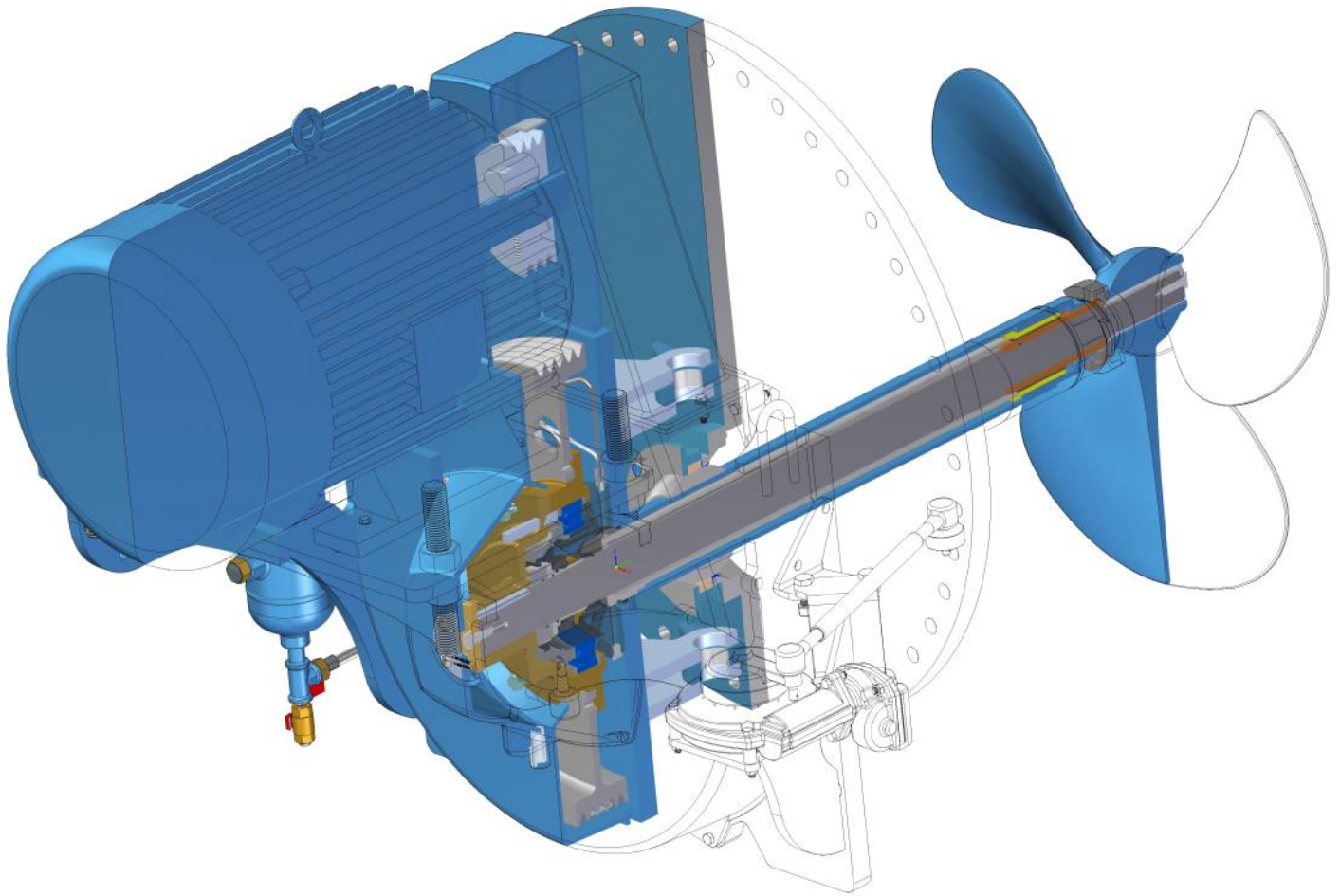

Jensen

Mixers International, Inc.

5354 SOUTH GARNETT ROAD, TULSA, OK 74147-5904 • P.O. BOX 470368, TULSA, OK 74147-0368
TELEPHONES: 918-627-5770 800-826-5646 • FAX 918-663-4939
WWW.JENSENMIXERS.COM